



# PHK-CHUCKS

High Performance Milling Chuck for running smoothness

# High Performance Milling Chuck

Process reliability especially in heavy machining

Pokolm presents its new heavyweights in the field of tool clamping.

For heavy-duty machining, firm and stable clamping forces of the tool are extremely important. They guarantee highest cutting performance and tooth feed under most difficult conditions with maximum process reliability.

Due to the safe clamping forces, Pokolm PHK holders promise a maximum tool extraction safety, even under high axial cutting and feed forces.

Benefit from the extreme stiffness and a maximum concentricity (3 µm at up to 3 x D) of drastically increased cutting volume and efficiency.

Secure the advantages such as maximum extraction safety of the tool, high concentricity through precise clamping technology, increase of the machining volume with absolute process reliability and an improvement of the tool life.

## Properties at a glance

- Especially high clamping torque of up to 2000 Nm
- Maximum concentricity deviation of 3 µm at 3 x D of the clamped tool
- Available as SK40/50 and HSK 63/100 connection
- Fine balanced at G 6.3 15,000 min-1
- Tool shanks with and without Weldon face can be used directly or with clamping sleeves\*

\* For clamping tools with cylindrical shank according to DIN 1835 Form A+B+E and DIN 6535 Form HB+HE



# SK 40 DIN 69 871 ADB

Ø 20 - Ø 32

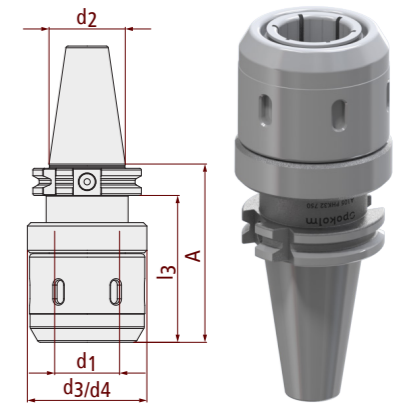

	Catalogue no.	d <sub>1</sub>	l <sub>3</sub>	A	d <sub>3</sub>	d <sub>4</sub>	d <sub>2</sub>	DIN/Form	l <sub>2</sub>	l <sub>1</sub>	Accessories	Features
Ø 20 - Ø 32	A90 PHK20 750	20	70,9	90	53	53	SK 40	DIN 69871 ADB	-	-	A, B, C, D, G	G 6.3 15.000
	A105 PHK25 750	25	85,9	105	63	63	SK 40	DIN 69871 ADB	-	-	A, B, C, E, H	G 6.3 15.000
	A105 PHK32 750	32	85,9	105	68	68	SK 40	DIN 69871 ADB	-	-	A, B, C, F, H	G 6.3 15.000

Accessories	A	B	C	D	E
	KBSK40-69872A	KBSK40-69872B	PHK ZB 01	PHK20 ZB 02	PHK25 ZB 01
	PHK32 ZB 01	PHK20 ZB 01	PHK25/32 ZB 01		

# SK 50 DIN 69 871 ADB

Ø 20 - Ø 32

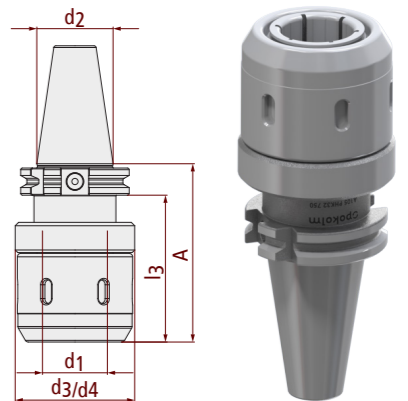

	Catalogue no.	d <sub>1</sub>	l <sub>3</sub>	A	d <sub>3</sub>	d <sub>4</sub>	d <sub>2</sub>	DIN/Form	l <sub>2</sub>	l <sub>1</sub>	Accessories	Features
Ø 20 - Ø 32	A90 PHK20 710	20	70,9	90	53	53	SK 50	DIN 69871 ADB	-	-	A, B, C, D, G	G 6.3 15.000
	A90 PHK25 710	25	70,9	90	63	63	SK 50	DIN 69871 ADB	-	-	A, B, C, E, H	G 6.3 15.000
	A90 PHK32 710	32	70,9	90	68	70	SK 50	DIN 69871 ADB	-	-	A, B, C, F, H	G 6.3 15.000

Accessories	A	B	C	D	E
	KBSK50-69872A	KBSK50-69872B	PHK ZB 01	PHK20 ZB 02	PHK25 ZB 01
	PHK32 ZB 01	PHK20 ZB 01	PHK25/32 ZB 01		

## HSK 63 Form A

Ø 20 - Ø 32

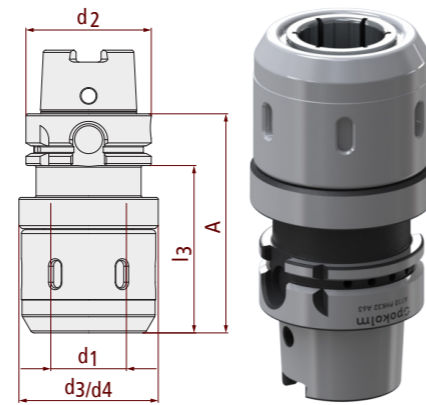

	Catalogue no.	d <sub>1</sub>	l <sub>3</sub>	A	d <sub>3</sub>	d <sub>4</sub>	d <sub>2</sub>	DIN/Form	l <sub>2</sub>	l <sub>1</sub>	Accessories	Features
Ø 20 - Ø 32	A95 PHK20 A63	20	69	95	53	53	HSK 63	Form A	-	-	A, B, C, F, H	
	A100 PHK25 A63	25	74	100	63	63	HSK 63	Form A	-	-	A, B, C, D, G	
	A110 PHK32 A63	32	84	110	68	68	HSK 63	Form A	-	-	A, B, C, E, H	

Accessories	A	B	C	D	E
	KMR-63A	SCHLUESSELHSK63	PHK ZB 01	PHK20 ZB 02	PHK25 ZB 01
	PHK32 ZB 01	PHK20 ZB 01	PHK25/32 ZB 01		

## HSK 100 Form A

Ø 20 - Ø 32

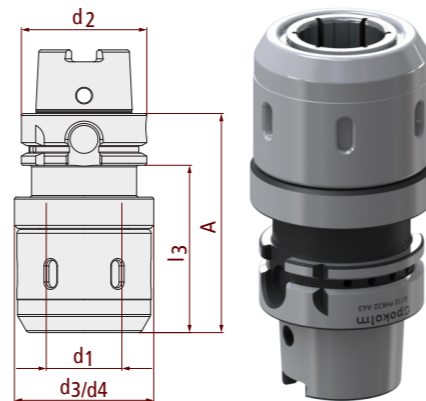

	Catalogue no.	d <sub>1</sub>	l <sub>3</sub>	A	d <sub>3</sub>	d <sub>4</sub>	d <sub>2</sub>	DIN/Form	l <sub>2</sub>	l <sub>1</sub>	Zubehör	Features
Ø 20 - Ø 32	A105 PHK20 A100	20	76	105	53	53	HSK 100	Form A	-	-	A, B, C, D, G	
	A105 PHK25 A100	25	76	105	63	63	HSK 100	Form A	-	-	A, B, C, E, H	
	A105 PHK32 A100	32	76	105	68	68	HSK 100	Form A	-	-	A, B, C, F, H	

Accessories	A	B	C	D	E
	KMR-100A	SCHLUESSELHSK100	PHK ZB 01	PHK20 ZB 02	PHK25 ZB 01
	PHK32 ZB 01	PHK20 ZB 01	PHK25/32 ZB 01		

## Reduction sleeve

for High Performance Milling Chuck PHK Ø 20

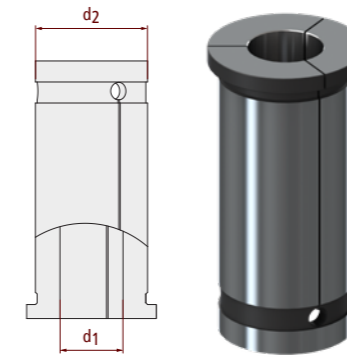

	Catalogue no.	d <sub>1</sub>	d <sub>2</sub>	Features
no internal cooling supply	PHK20 6	6	20	
	PHK20 8	8	20	
	PHK20 10	10	20	
	PHK20 12	12	20	
	PHK20 14	14	20	
	PHK20 16	16	20	



	Catalogue no.	d <sub>1</sub>	d <sub>2</sub>	Features
internal cooling supply	PHK20 3 IC	3	20	
	PHK20 4 IC	4	20	
	PHK20 5 IC	5	20	
	PHK20 6 IC	6	20	
	PHK20 8 IC	8	20	
	PHK20 10 IC	10	20	
	PHK20 12 IC	12	20	
	PHK20 14 IC	14	20	
	PHK20 16 IC	16	20	

## Reduction sleeve

for High Performance Milling Chuck PHK Ø 25

	Catalogue no.	d <sub>1</sub>	d <sub>2</sub>	Features
no internal cooling supply	PHK25 6	6	25	
	PHK25 8	8	25	
	PHK25 10	10	25	
	PHK25 12	12	25	
	PHK25 14	14	25	
	PHK25 16	16	25	
	PHK25 18	18	25	
	PHK25 20	20	25	

	Catalogue no.	d <sub>1</sub>	d <sub>2</sub>	Features
internal cooling supply	PHK25 3 IC	3	25	
	PHK25 4 IC	4	25	
	PHK25 5 IC	5	25	
	PHK25 6 IC	6	25	
	PHK25 8 IC	8	25	
	PHK25 10 IC	10	25	
	PHK25 12 IC	12	25	
	PHK25 14 IC	14	25	
	PHK25 16 IC	16	25	
	PHK25 18 IC	18	25	
PHK25 20 IC	20	25		

# Reduction sleeve

for High Performance Milling Chuck PHK Ø 32

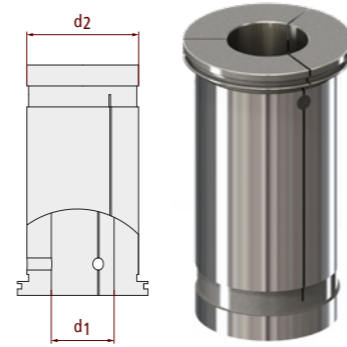
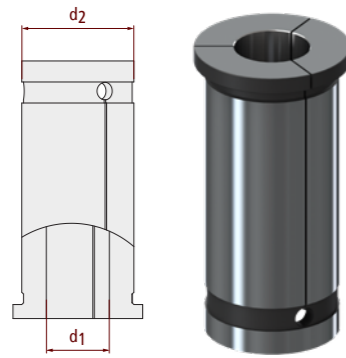

	Catalogue no.	d <sub>1</sub>	d <sub>2</sub>	Features
no internal cooling supply	PHK32 6	6	32	✓ HSC
	PHK32 8	8	32	✓ HSC
	PHK32 10	10	32	✓ HSC
	PHK32 12	12	32	✓ HSC
	PHK32 14	14	32	✓ HSC
	PHK32 16	16	32	✓ HSC
	PHK32 18	18	32	✓ HSC
	PHK32 20	20	32	✓ HSC
	PHK32 25	25	32	✓ HSC

	Catalogue no.	d <sub>1</sub>	d <sub>2</sub>	Features
internal cooling supply	PHK32 3 IC	3	32	✓ HSC
	PHK32 4 IC	4	32	✓ HSC
	PHK32 5 IC	5	32	✓ HSC
	PHK32 6 IC	6	32	✓ HSC
	PHK32 8 IC	8	32	✓ HSC
	PHK32 10 IC	10	32	✓ HSC
	PHK32 12 IC	12	32	✓ HSC
	PHK32 14 IC	14	32	✓ HSC
	PHK32 16 IC	16	32	✓ HSC
	PHK32 18 IC	18	32	✓ HSC
	PHK32 20 IC	20	32	✓ HSC
	PHK32 25 IC	25	32	✓ HSC

# Accessories

	Catalogue no.	Description				
<b>Coolant supply tube for HSK tooling</b>						
	KMR-63A	Coolant supply tube for HSK-tooling	for HSK 63	Form A + E		
	KMR-100A	Coolant supply tube for HSK-tooling	for HSK 100	Form A		
<b>Spanners for coolant supply tube</b>						
	SCHLUESSELHSK63	Montageschlüssel für Kühlmittelröhrchen	HSK 63			
	SCHLUESSELHSK100	Montageschlüssel für Kühlmittelröhrchen	HSK 100			
<b>Retention knobs with seal ring groove</b>						
	KBSK40-69872A	Retention knob with through hole	SK 40	DIN 69 872 A	with seal ring groove	
	KBSK50-69872A	Retention knob with through hole	SK 50	DIN 69 872 A	with seal ring groove	
<b>Retention knobs with seal ring groove</b>						
	KBSK40-69872B	Retention knob without through hole	SK 40	DIN 69 872 B	with seal ring groove	
	KBSK50-69872B	Retention knob without through hole	SK 50	DIN 69 872 B	with seal ring groove	
<b>PHK Extractor</b>						
	PHK ZB 01	Extractor for reduction sleeves for system PHK				
<b>PHK Setting screw</b>						
	PHK20 ZB 02	Setting screw PHK20 for High Performance Milling Chuck				
	PHK25 ZB 01	Setting screw PHK25 for High Performance Milling Chuck				
	PHK32 ZB 01	Setting screw PHK32 for High Performance Milling Chuck				
<b>PHK Wrench</b>						
	PHK20 ZB 01	Wrench for clamping nuts PHK 20				
	PHK25/32 ZB 01	Wrench for clamping nuts PHK 25 und PHK 32				

## Pokolm Frästechnik GmbH & Co. KG

---

Adam-Opel-Straße 5, 33428 Harsewinkel - Germany  
+49 5247 9361-0, info@pokolm.de



[www.pokolm.de](http://www.pokolm.de)