

COLD FORGING WITH FORGEfix® BENEFITS AT A GLANCE

- Processing also complex tool- and mould surfaces according to NC datasets
- Using on machines such as standard CNC tooling machines, robots or similar
- No negative thermal effects (such as those caused by long runtimes during electrodynamic cold forging)
- Handy tool
- Can automatically be exchanged (if using internal coolant supply)

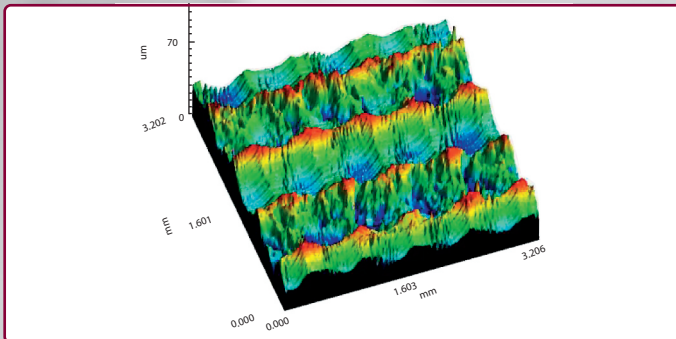

Practical video:
FORGEfix® in 1.2312



Surface after ball milling with pronounced roughness peaks

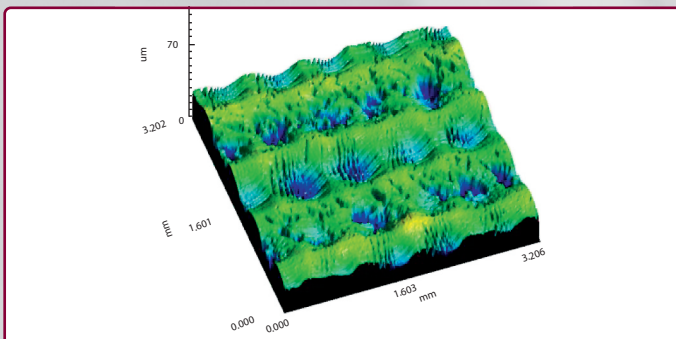

Tribologically optimised surface after cold forge processing

TECHNICAL DATA

Length:	195 mm
Diameter:	40 mm
Threaded shank:	M16 or Ø 20
Stroke adjustment:	from 0 to 4 mm
Air connection (ICS* or extern)	6 bar
Frequency (f at 6 bar):	about 250 Hz

*Internal Coolant Supply

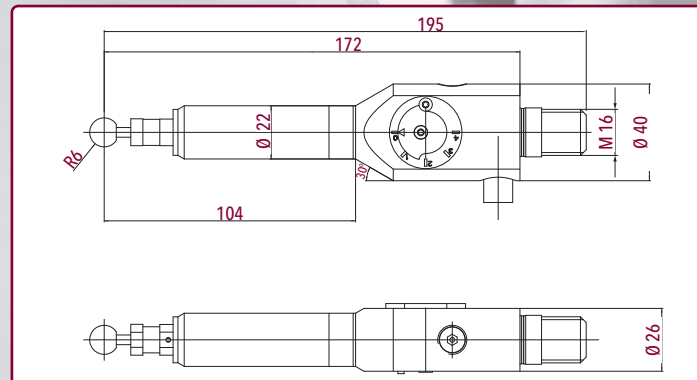

All values in mm. Changes reserved.

Development partner and Sales distribution:

Pokolm Frästechnik GmbH & Co. KG

Adam-Opel-Straße 5

33428 Harsewinkel

Germany

fon: +49 5247 9361-0

fax: +49 5247 9361-99

info@pokolm.com

www.pokolm.com



FORGEfix®

PNEUMATIC COLD FORGING PRECISION TOOL



pokolm
PREMIUMTOOLS. WE KNOW HOW.

FORGEfix® - PNEUMATIC COLD FORGING PRECISION TOOL FOR MECHANICAL WORKPIECE SURFACE TREATMENT

The pneumatic cold forging tool FORGEfix® with threaded shank M16 or weldon Ø 20 is now available for the high-quality, economical and reproducible smoothing also of complex surfaces.

To the now common method of manual polishing for highquality surfaces in the tool- and mould-making is high due to lack of time, effort and reproducibility very disadvantageous.

Cold forging

- is a process for mechanical surface treatment
- in which a hammering tool is moved systematically over the workpiece surface by a CNC tooling machine or a robot or similar systems
- is compared to known methods a superior method of surface treatment. Known methods such as shot blasting, form grinding, deep rolling or laser polishing



Use of FORGEfix® for cold forging of batch drawing tools on a robot system



The surface is processed line-by-line. Millions of contact points ensure a very high homogeneous surface.

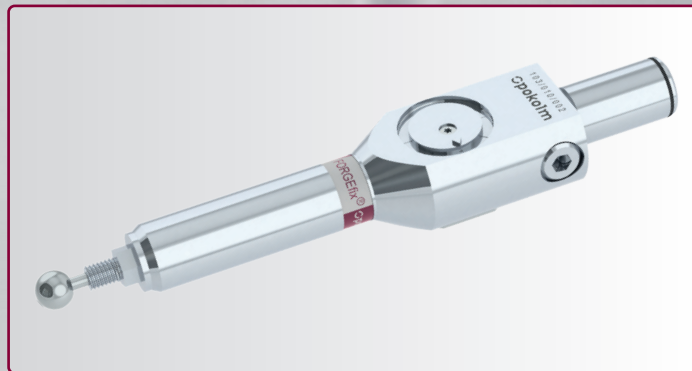

FORGEfix® - pneumatic cold forging tool with stroke adjustment, exclusively available from Pokolm with threaded shank M16 or weldon Ø 20

COLD FORGING **BENEFITS** ALL METHODS

- Machine smoothing significantly reduces the high time and cost outlay of manual surface finishing in tool- and mould-making.
- In addition, customised structures can be created, such as lubrication pockets which help to improve friction properties.
- Increased surface hardening through cold solidification reduces wear not only on forming tools, but also on all types of metallic bearings and guides.
- Optimised distribution of residual stress prevents the formation of cracks on components subject to variations in stress, thus increasing their service life.

FORGEfix® RANGE OF PRODUCTS

Catalogue no.	Article
FFP-BASIC	FORGEfix-BASIC-M16 Cold forging systems
	Setup: 500N[SP], 250N[LP] and 1000N[HP]
FFP-BASIC-ZB	Cold forging systems accessories
FFP-ZB-K-08	FORGEfix knock ball, diameter 8 mm
FFP-ZB-K-10	FORGEfix knock ball, diameter 10 mm
FFP-ZB-K-12	FORGEfix knock ball, diameter 12 mm
FFP-ZB-K-16	FORGEfix knock ball, diameter 16 mm
FFP-ZB-K-20	FORGEfix knock ball, diameter 20 mm
FFP-ZB-ST-L	Ram long cone for knock balls, diameter 8 - 20 mm
FFP-ZB-ST-L-1	Ram long cone for knock balls, diameter 1 mm
FFP-ZB-ST-L-2	Ram long cone for knock balls, diameter 2 mm
FFP-ZB-ST-L-3	Ram long cone for knock balls, diameter 3 mm
FFP-ZB-ST-L-4	Ram long cone for knock balls, diameter 4 mm
FFP-ZB-ST-L-6	Ram long cone for knock balls, diameter 6 mm
FFP-ZB-ST-L-8	Ram long cone for knock balls, diameter 8 mm
FFP-ZB-ST-L-10	Ram long cone for knock balls, diameter 10 mm
FFP-ZB-ST-L-12	Ram long cone for knock balls, diameter 12 mm